



MKB 752



BANDSÄGEN BAND SAWS

MKB 749 – 758

Bandsägen

Mit einem Schnittdurchlass von 230 – 500 mm umfasst unser Sortiment an Bandsägen für jede Anwendung die richtige Durchlasshöhe.

Das Finger Protection System (FPS) sorgt für die optimale Sicherheit des Bedieners.

Löst der integrierte optische Sensor der Säge aus, wird die Bandsäge automatisch, binnen weniger Millisekunden durch das Sicherheitssystem gestoppt. Im Anschluss kann die Maschine wieder wie gewohnt gestartet werden.

Eine Erneuerung des Sägebandes ist auch nach mehrmaligem Auslösen der Sicherheitsfunktion nicht erforderlich. Das FPS ist für die MADO Bandsägen MKB 751 – 754 erhältlich.

Die MADO typische Edelstahlkonstruktion der Maschine, inkl. der Laufräder, ist selbstverständlich und erlaubt eine leichte und hygienische Reinigung.

MADO Bandsägen sind optional mit vielfältigen Sonderausstattungen erhältlich.

MKB 749



MKB 750



Band Saws

With a cutting height of 230 – 500 mm, our range of band saws includes the right admission height for every application.

The Finger Protection System (FPS) provides optimal security for the operator.

As soon as the integrated optical sensor triggers, the band saw is stopped automatically within a few milliseconds. In case the machine was stopped by the security system, it can be turned on again as usual.

Even after repeated trigger of the security system a renewal of the saw band is not necessary. The FPS is available for the band saw models MKB 751 – 754.

The MADO typical stainless steel construction of the machine, including the wheels, is a matter of course and allows easy and hygienic cleaning.

MADO band saws are optionally customizable with a wide range of special equipment.

MKB 753



Zu jeder Zeit der richtige Schnitt

The right cut at all times

FPS

Finger Protection System

Serienausstattung:

- Portionierer (MKB 749 – 757)
- Knochenmehlbehälter
- Andrückvorrichtung (MKB 749)
- Abnehmbare Andrückvorrichtung (MKB 750 – 758)
- Höhenverstellbarer Bandschutz (MKB 750 – 758)
- Festtisch (MKB 749, 750, 751, 753, und 757)
- Schiebetisch (MKB 752, 754 und 756)
- Rollentisch (MKB 758)

Optionen:

- FPS Version (MKB 751 – 754)
- Wandkonsole (MKB 749)
- Aufsatzschiebetisch (MKB 750, 751, 753)
- Schnellläufer (MKB 756 – 758)
- Linksausführung (MKB 749 – 754)

Basic version:

- Portionierer (MKB 749 – 757)
- Bone-meal container
- „Feed-on and safe cut“ guide (MKB 749)
- Removable „feed-on and safe cut“ guide (MKB 750 – 758)
- Height adjustable blade shield (MKB 750 – 758)
- Fixed table (MKB 749, 750, 751, 753, and 757)
- Sliding table (MKB 752, 754 and 756)
- Roller table (MKB 758)

Options:

- FPS version (MKB 751 – 754)
- Wall bracket (MKB 749)
- Additional sliding table (MKB 750, 751, 753)
- Enhanced cutting speed (MKB 756 – 758)
- Left-hand version (MKB 749 – 754)

MKB 754



MKB 758



MKB 752 FPS



FPS Finger Protection System eine von MADO entwickelte Technologie zur Gefahrenminimierung. Es handelt sich hierbei um eine erweiterte Schutzeinrichtung, die durch ein kameraüberwachtes Bandstoppsystem das Sägeband innerhalb von wenigen Millisekunden zum Stillstand bringt.

FPS Finger Protection System is a developed technology by MADO to minimize risks. It is an extended protection device which brings the saw band to a standstill within a few milliseconds using a camera monitored band-stop system.

Informationen Information

Informationen Information

MKB 749 D/W

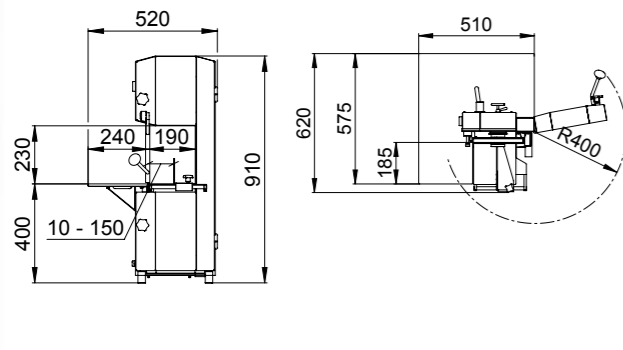

MKB 750

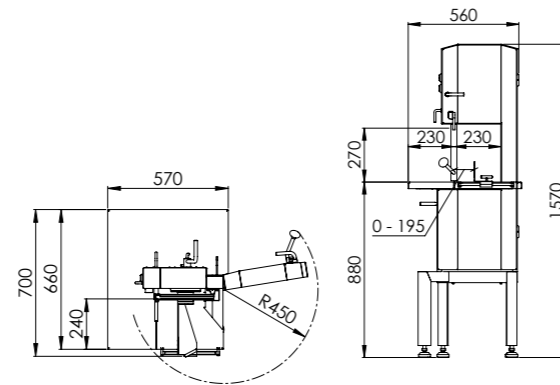

MKB 751

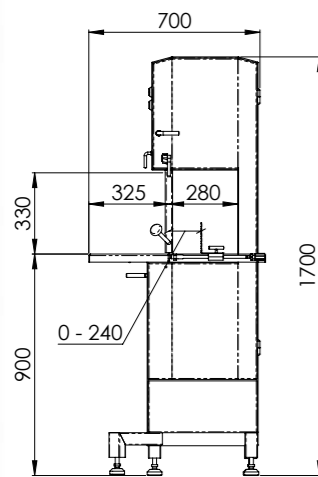

MKB 752

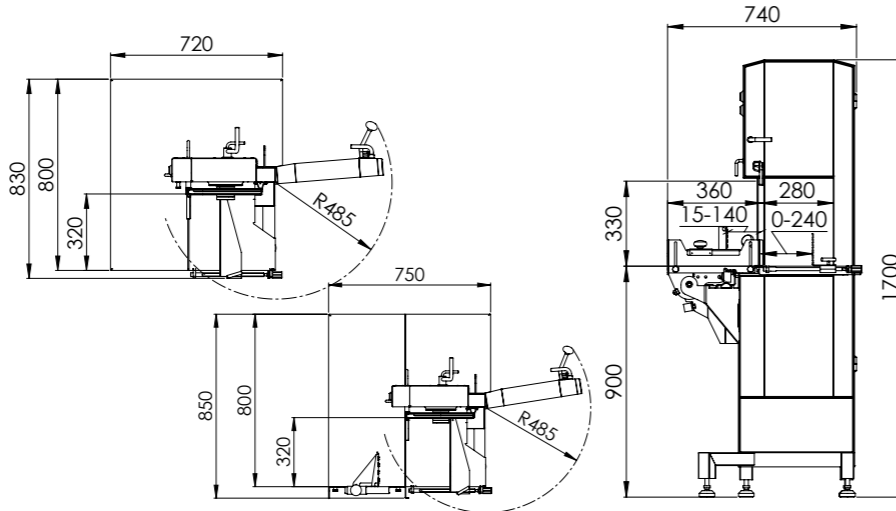

MKB 753

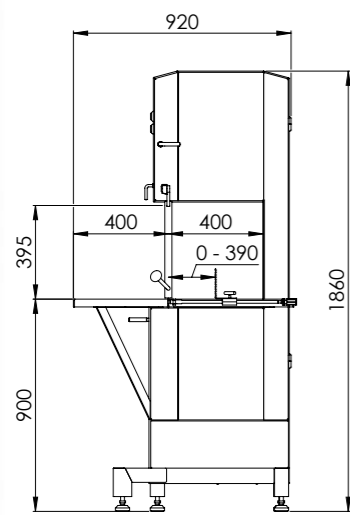

MKB 754

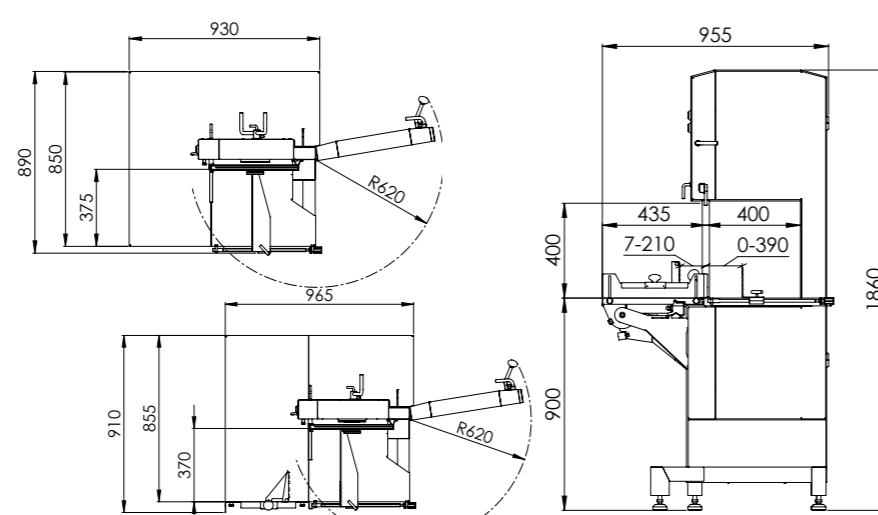

MKB 756

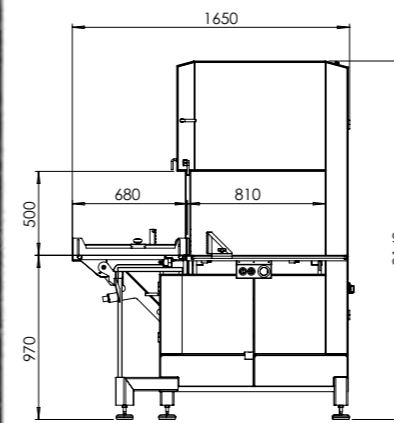

MKB 757

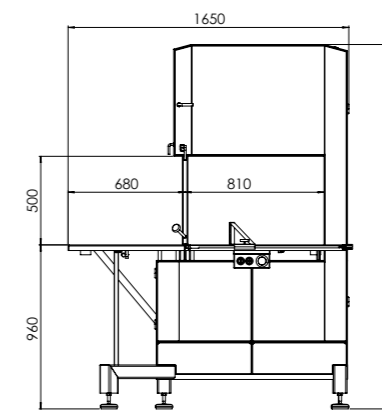

MKB 758

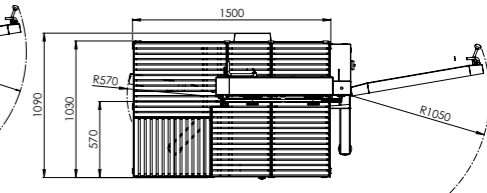
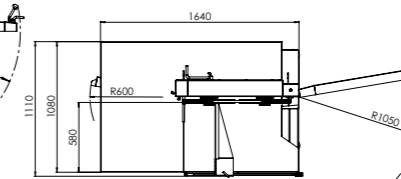
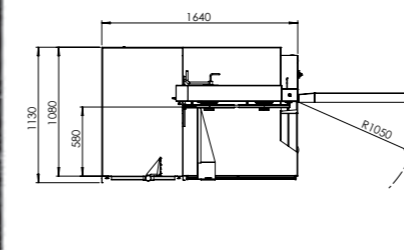
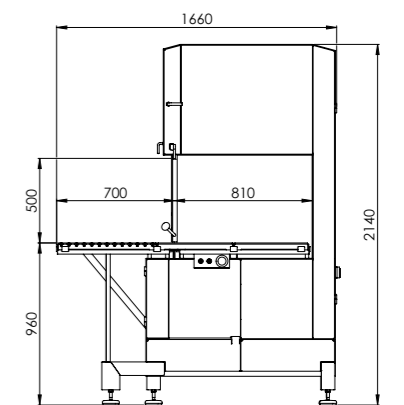

Maßangaben in mm / Dimensions in mm

	MKB 749 D/W	MKB 750	MKB 751	MKB 752	MKB 753	MKB 754	MKB 756	MKB 757	MKB 758
Motorspannung / Motor voltage	400 V, 50 Hz, Drehstrom / 230 V, 50 Hz, Wechselstrom / 400 V, 50 Hz, 3-phase AC 230 V, 50 Hz single-phase AC	400 V, 50 Hz, Drehstrom / 400 V, 50 Hz, 3-phase AC	400 V, 50 Hz, Drehstrom / 400 V, 50 Hz, 3-phase AC	400 V, 50 Hz, Drehstrom / 400 V, 50 Hz, 3-phase AC	400 V, 50 Hz, Drehstrom / 400 V, 50 Hz, 3-phase AC	400 V, 50 Hz, Drehstrom / 400 V, 50 Hz, 3-phase AC	400 V, 50 Hz, Drehstrom / 400 V, 50 Hz, 3-phase AC	400 V, 50 Hz, Drehstrom / 400 V, 50 Hz, 3-phase AC	400 V, 50 Hz, Drehstrom / 400 V, 50 Hz, 3-phase AC
Motorleistung / Motor capacity	1,1 kW	1,1 kW	1,5 kW	1,5 kW	2,2 kW	2,2 kW	4,0 kW	4,0 kW	4,0 kW
Netzabsicherung / Fuse protection	16 A träge / inert	16 A träge / inert	16 A träge / inert	16 A träge / inert	16 A träge / inert	16 A träge / inert	16 A träge / inert	16 A träge / inert	16 A träge / inert
Drehzahlen / Speed / r.p.m.	1440 U/min. / r.p.m.	1440 U/min. / r.p.m.	1445 U/min. / r.p.m.	1445 U/min. / r.p.m.	970 U/min. / r.p.m.	970 U/min. / r.p.m.	970 U/min. / r.p.m.	970 U/min. / r.p.m.	970 U/min. / r.p.m.
Schnittgeschw. / Cutting speed	17 m/sec.	20 m/sec.	22 m/sec.	22 m/sec.	22 m/sec.	22 m/sec.	22 m/sec.	22 m/sec.	22 m/sec.
Schnittbreite max. / Cutting width max.	190 mm	230 mm	280 mm	280 mm	400 mm	400 mm	810 mm	810 mm	810 mm
Schnitthöhe max. / Cutting height max.	230 mm	270 mm	330 mm	330 mm	395 mm	400 mm	500 mm	500 mm	500 mm
Bandsägeblatt / Bandsaw blade	1750 x 16 mm	2170 x 16 mm	2430 x 16 mm	2430 x 16 mm	3150 x 16 mm	3150 x 16 mm	4455 x 16 mm	4455 x 16 mm	4455 x 16 mm
Gewicht / Weight	ca. / approx. 65 kg	ca. / approx. 115 kg	ca. / approx. 170 kg	ca. / approx. 190 kg	ca. / approx. 220 kg	ca. / approx. 240 kg	ca. / approx. 525 kg	ca. / approx. 500 kg	ca. / approx. 500 kg

FPS Version: Für den Betrieb ist ein Druckluftanschluss (7–8 bar) notwendig. Gewicht + ca. 15 kg.
FPS version: A compressed air connection (7–8 bar) is required for operation. Weight + approx. 15 kg.
 Änderungen vorbehalten / Subject to change